

# Differential Measurement

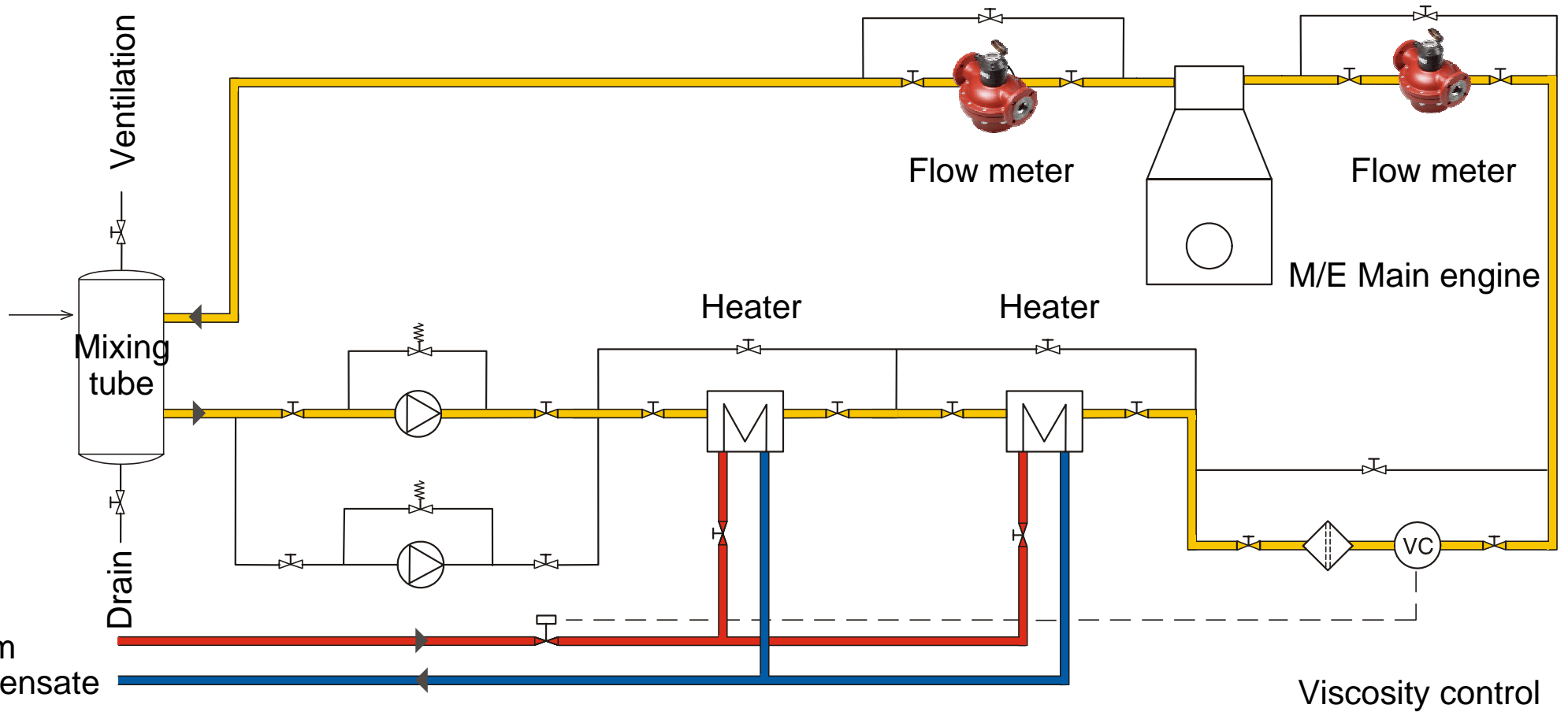

2 x VZxA 180°C for differential measurement.



Flow measurement in the circulation after mixing tube

# Differential Measurement



## CONTOIL<sup>®</sup> Meter Burden

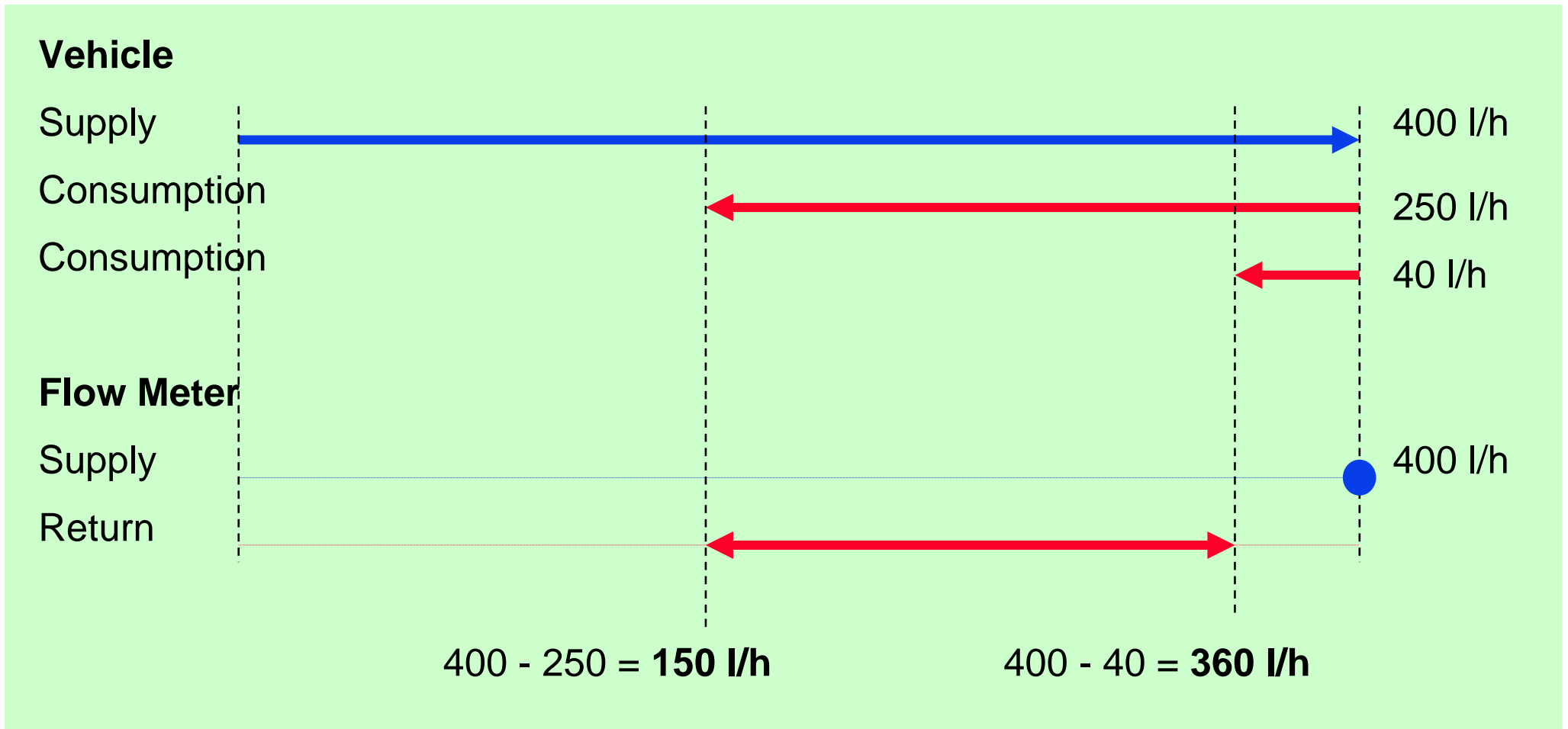

# Differential Measurement

## CONTOIL® VZOA

- DN 15...50
- 180°C version
- Up to PN25
- JIS or DIN flanges
- VZO: no outputs, roller counter
- VZF: 2 outputs plus digital display
- 0,3 (0,1)% accuracy with special calibration

Typical meter: VZFAxx FL 180/25

